

Spezial Hallenkran

Die Abmessungen

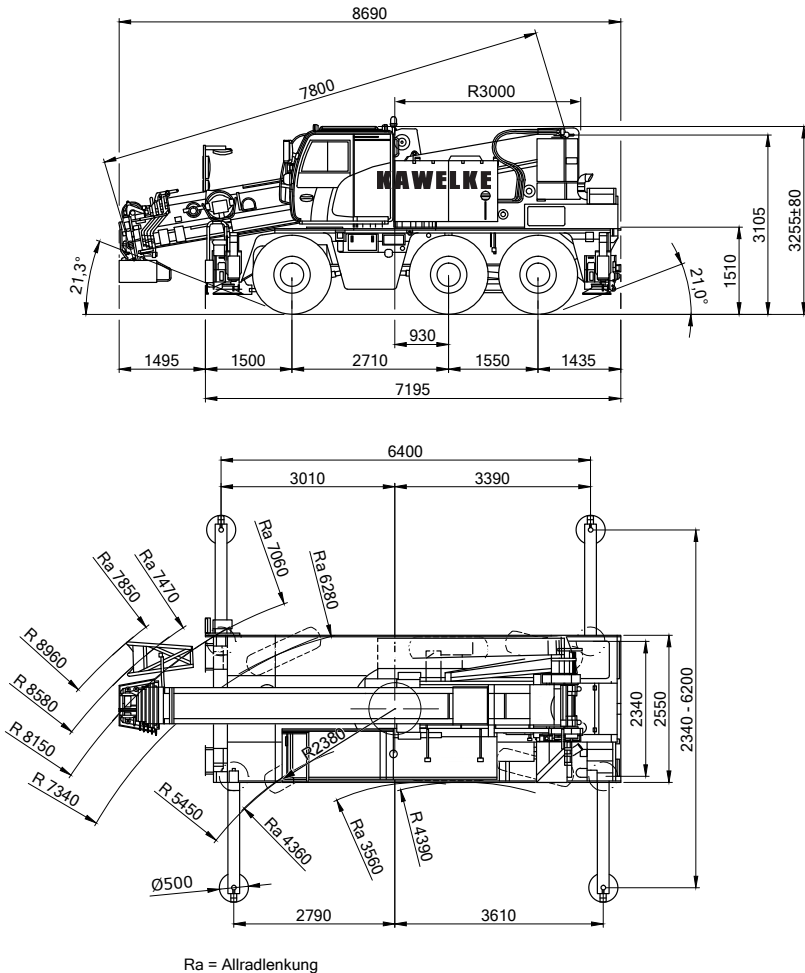

Die Arbeitsbereiche

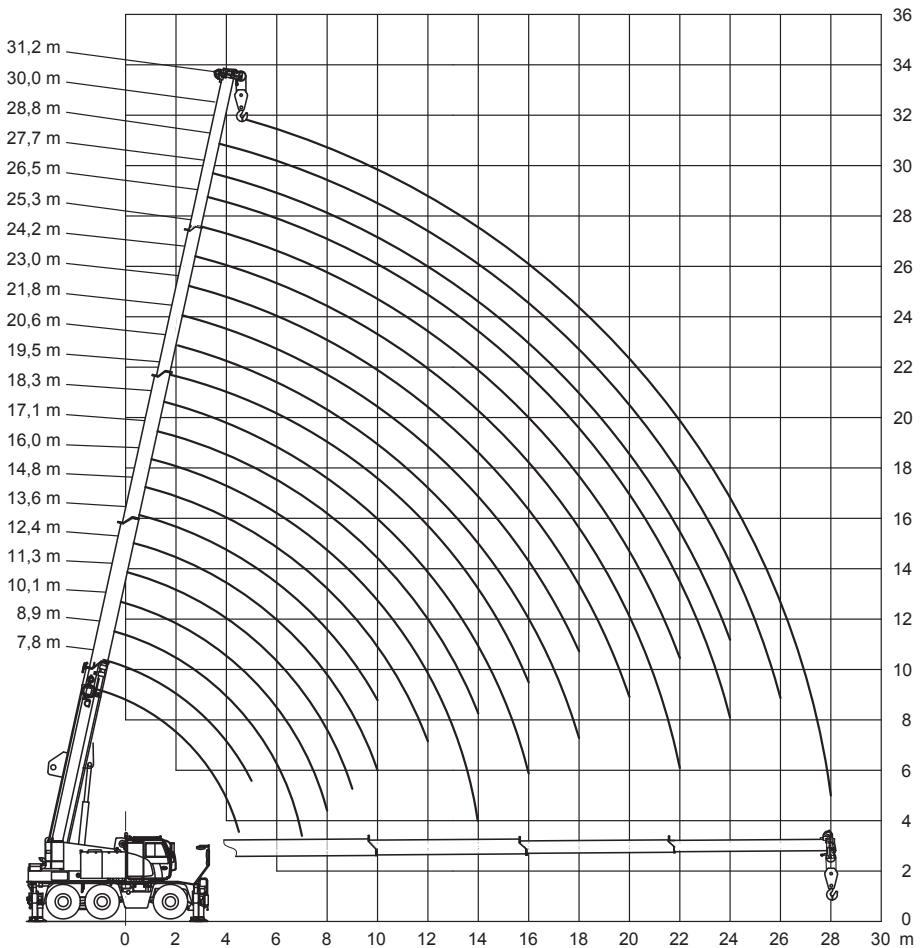



7,8-31,2m



5,25t



6,4x6,2m



360°



4305

2,5	7,8*	7,8	8,9	11,3	13,6	18,3	21,8	26,5	31,2	2,5
2,5	50									2,5
3	45	35,3	25	25	25	16				3
3,5	36,5	33,2	25	25	25	16	16			3,5
4	31,9	31,3	25	25	25	16	16			4
4,5	28,4	28,4	25	25	24,4	16	16			4,5
5			25	24,9	23,2	16	16			5
6				20,2	19,9	16	16	16		6
7				16,8	16,5	16	16	15,6	10,8	7
8				15	15,1	15,6	15,2	14	10	8
9					12,3	12,7	12,7	11,9	9,3	9
10					10,2	10,7	10,8	10,5	8,7	10
12						7,9	8	7,7	7,5	12
14						6,2	6,3	6	5,8	14
16							5,1	5	4,6	16
18							4,2	4,1	3,7	18
20								3,4	3	20
22								2,9	2,4	22
24									2	24
26									1,6	26
28									1,3	28

* 180° nach vorne mit Schwerlastausrüstung

Die Arbeitsbereiche

Lange Absteckung
29,4°

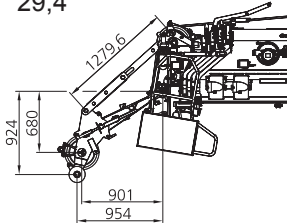

Mittlere Absteckung
-0,8°

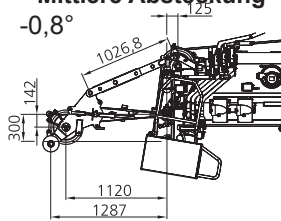

Kurze Absteckung
-19°

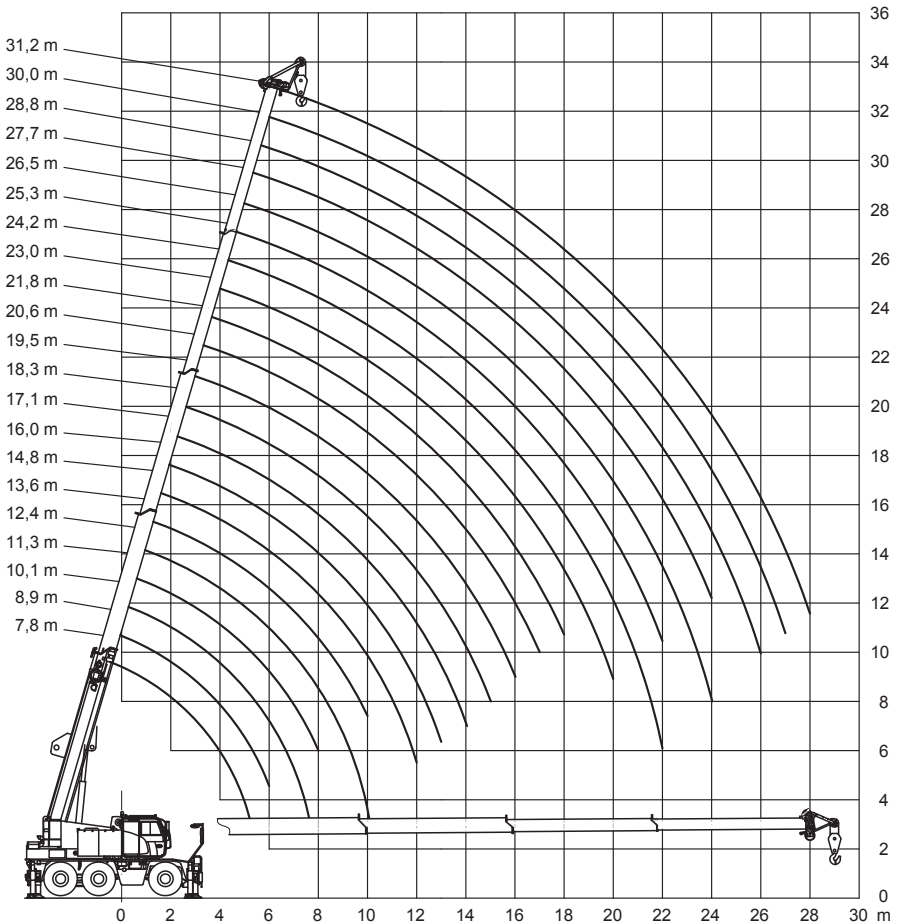
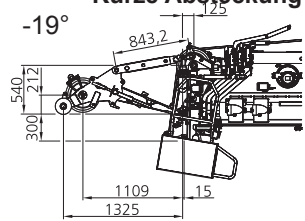

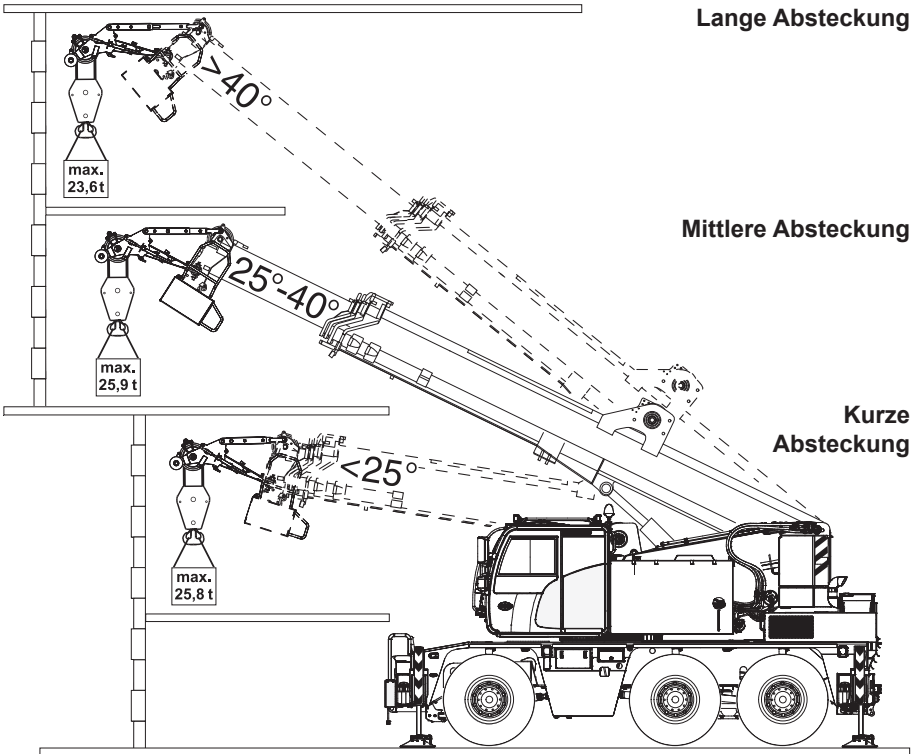



7,8-31,2m

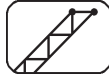

1,3m / 29,4°



5,25t





6,4x6,2m



360°



4305

	7,8	8,9	11,3	13,6	18,3	21,8	26,5	31,2	
3	21,2	21,9	22,9	23,3	16				3
3,5	20,6	21,2	22,7	23	16				3,5
4	20,1	20,6	22,1	22,1	16				4
4,5	19,3	20,2	21,5	21,2	16	16			4,5
5	18,1	19,7	21	20,2	16	16			5
6		18	20,1	18	16	16			6
7		17,3	17,1	16	16	15,6	13,7		7
8			15,3	15,3	15,4	14,5	12,8	9,2	8
9			12,4	12,5	12,5	12,4	11,8	8,6	9
10				10,4	10,8	10,6	10,2	8	10
11					9,4	9,5	9,1	7,5	11
12					8	8,1	7,8	7,1	12
13					7,1	7,2	6,9	6,6	13
14					6,2	6,3	6	5,8	14
15					5,6	5,6	5,4	5,2	15
16					4,9	5	4,9	4,6	16
17						4,6	4,5	4,1	17
18						4,1	4	3,7	18
19							3,7	3,3	19
20							3,3	2,9	20
21							3,1	2,7	21
22							2,8	2,4	22
23							2,5	2,1	23
24							2,3	1,9	24
25								1,7	25
26								1,5	26
27								1,4	27
28								1,2	28



7,8-31,2m

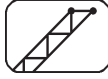

1,3m / -0,8°



5,25t





6,4x6,2m



360°



4305

	7,8	8,9	11,3	13,6	18,3	21,8	26,5	31,2	
4	25,9								4
4,5	25,9	25							4,5
5	25,8	25							5
6	21	20,7							6
7		17,3	17						7
8			15,2	15,2					8
9			12,4	12,4					9
10				10,4					10
11				8,8	9,1				11
12					7,9				12
13					6,9				13
14					6,2	6,2			14
15					5,5	5,6			15
16					4,9	5			16
17						4,5	4,4		17
18						4,1	4		18
19						3,7	3,6		19
20							3,3	2,9	20
21							3	2,6	21
22							2,7	2,3	22
23							2,5	2,1	23
24							2,3	1,9	24
25								1,7	25
26								1,5	26
27								1,3	27
28								1,2	28
29								1,1	29



7,8-31,2m

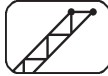

1,3m / -19°



5,25t





6,4x6,2m



360°



4305

	7,8	8,9	11,3	13,6	18,3	21,8	26,5	27,7	31,2	
5	25,7									5
6		20,6								6
7		17,3								7
8										8
9			12,3							9
10										10
11				8,8						11
12										12
13										13
14										14
15					5,5					15
16					4,9					16
17										17
18						4,1				18
19						3,7				19
20										20
21										21
22							2,7			22
23							2,5	2,4		23
24							2,3	2,2		24
25								2		25
26									1,5	26
27									1,3	27
28									1,2	28
29									1,1	29